



Description:

Metal housing, 150m laser opposed, 30m laser retro-reflective, 25m laser polarized retro-reflective, 3m laser BGS diffuse, coaxial technology, no blind zone, precise positioning, wide voltage supply, relay output. Suitable for automotive manufacturing, metallurgical industry, non-standard equipment, textile machinery and others.

Features:

- BGS function greatly improves the detection effect
- Long detection distance
- Adjust the sensitivity by knob
- IP67 protection class
- Push-pull / relay output

Type: (light source-laser)

Detection mode	Type	Distance	Light source	Frequency	Output	Switching mode	Connection	Wiring
Opposed	OSM70-SL6	150m	Laser	— —	— —	— —	2m cable	Fig.1
	OSM70-ELVB6		— —	800Hz	Push-Pull	Light on / dark on	2m cable	Fig.4
	OSM70-SL6Q	150m	Laser	— —	— —	— —	M12 4-pin connector	Fig.2
	OSM70-ELVB6Q		— —	800Hz	Push-Pull	Light on / dark on	M12 4-pin connector	Fig.4
	OSM70-SL5	150m	Laser	— —	— —	— —	2m cable	Fig.3
	OSM70-ELVR5		— —	50Hz	Relay	Light on / dark on	2m cable	Fig.5
Retro-reflective	OSM70-RLVB6	30m	Laser	800Hz	Push-Pull	Light on / dark on	2m cable	Fig.6
	OSM70-RLVB6Q	30m	Laser	800Hz	Push-Pull	Light on / dark on	M12 4-pin connector	Fig.4
	OSM70-RLVR5	30m	Laser	50Hz	Relay	Light on / dark on	2m cable	Fig.5
Polarized retro-reflective	OSM70-RPLVB6	25m	Laser	800Hz	Push-Pull	Light on / dark on	2m cable	Fig.6
	OSM70-RPLVB6Q	25m	Laser	800Hz	Push-Pull	Light on / dark on	M12 4-pin connector	Fig.4
	OSM70-RPLVR5	25m	Laser	50Hz	Relay	Light on / dark on	2m cable	Fig.5
BGS TOF	OSM70-AKL3000VB6	3m	Infrared laser + Laser indication	20-50Hz	Push-Pull	Light on / dark on	2m cable	Fig.6
	OSM70-AKL3000VB6Q	3m	Infrared laser + Laser indication	20-50Hz	Push-Pull	Light on / dark on	M12 4-pin connector	Fig.4
	OSM70-AKL3000VR5	3m	Infrared laser + Laser indication	20-50Hz	Relay	Light on / dark on	2m cable	Fig.5
	OSM70-AKL3000C2B6	3m	Infrared laser + Laser indication	20-50Hz	2xPush-Pull	Light on / dark on	2m cable	Fig.7
	OSM70-AKL3000C2B6Q	3m	Infrared laser + Laser indication	20-50Hz	2xPush-Pull	Light on / dark on	M12 4-pin connector	Fig.8
BGS TOF	OSM70-AKL4000VB6	4m	Infrared laser + Laser indication	20-50Hz	Push-Pull	Light on / dark on	2m cable	Fig.6
	OSM70-AKL4000VB6Q	4m	Infrared laser + Laser indication	20-50Hz	Push-Pull	Light on / dark on	M12 4-pin connector	Fig.4
	OSM70-AKL4000VR5	4m	Infrared laser + Laser indication	20-50Hz	Relay	Light on / dark on	2m cable	Fig.5
	OSM70-AKL4000C2B6	4m	Infrared laser + Laser indication	20-50Hz	2xPush-Pull	Light on / dark on	2m cable	Fig.7
	OSM70-AKL4000C2B6Q	4m	Infrared laser + Laser indication	20-50Hz	2xPush-Pull	Light on / dark on	M12 4-pin connector	Fig.8

Technical Data:

Operating voltage	10...30VDC (push-pull), 24...240VAC/DC (relay)
Ripple voltage	≤10%
Switch output	Push-Pull, Relay
Output characteristics	Light on + dark on
Repeatability	≤3%
light source	Opposed/retroreflective: red laser (655 nm)/class 2; TOF: infrared laser (940 nm) + indication laser (655 nm)/class 1
Spot diameter	5mm@7m, 15mm@20m(Opposed, Etro-reflective); 2*4cm@1m, 7*5cm@2m, 10*7cm@3m(Diffuse detection light source)
No-load current	≤30mA
Load current	≤450mA (push-pull), ≤3A (relay)
Protection circuit	Reverse polarity protection (push-pull), short circuit protection, surge protection (relay), overload protection
Output indicator	Red LED
Steady state indicator	Green LED
Housing material	Die cast zinc
Connection	M12 connector / 2 meter cable
Operating temperature	-25 °C...5 5°C; -30 °C...55 °C(OSM70-AKL4000)
Storage temperature	-40 °C...70 °C
Detection mode	BGS, Window mode, FGS (OSM70-AKL3000)
Voltage resistance	1000V/AC 50/60Hz 60s
Insulation impedance	≥50MΩ (500VDC)
Shock resistance	Complex amplitude 1.5mm 10... 50Hz (2hr X, Y,Z respectively)
Impact resistance	500m/S2(50G) 3 times X, Y, Z respectively
Protection class	IP67
Dimensions	27×54×84mm

Wiring:

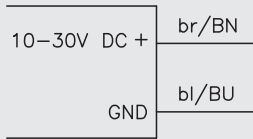

Fig.1

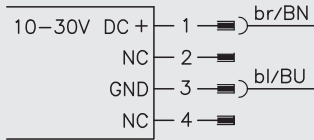

Fig.2

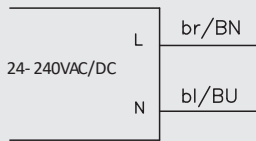

Fig.3

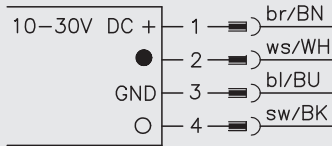

Fig.4

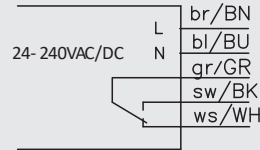

Fig.5

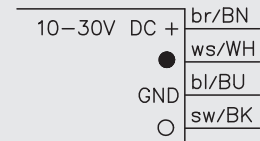

Fig.6

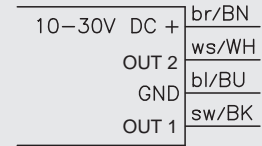

Fig.7

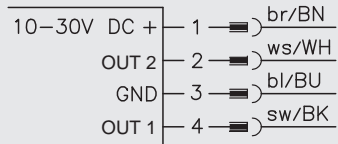
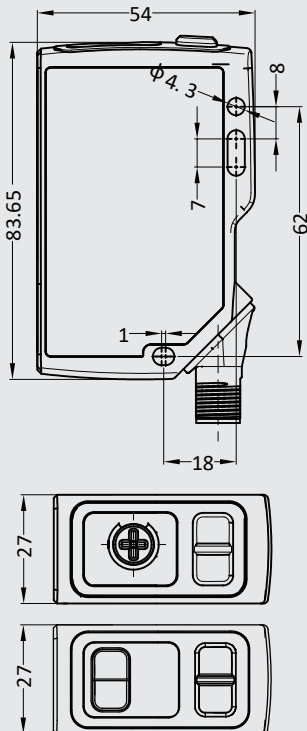

Fig.8

Dimensions:

M12 connector



2m cable

